

PSENmag PSEN ma1.3a/b-20



Unit features

- ▶ The actuator **PSEN ma1,3-08** belongs to the safety switch
- ▶ Safety switch with cable (5 m/ 10 m)
- ▶ 2 reed contacts (N/O)
- ▶ 1 auxiliary contact (N/O)
- ▶ Assured operating distance: **8 mm**
- ▶ Assured release distance: **15 mm**
- ▶ Safety switch and actuator with M12 round design
- ▶ Works magnetically
- ▶ Switching voltage 24 VDC
- ▶ LED to display switch status

Magnetic safety switches for monitoring the position of movable guards in accordance with EN 60947-5-3



Unit description

The safety switch meets the requirements of EN 60204-1 and IEC 60204-1.

The safety switch only complies with EN 60947-5-3 in conjunction with the actuator **PSEN ma1,3-08** and its approved evaluation devices.

The safety switch should only be connected to the evaluation devices listed under "Connections".

Approvals

	PSEN ma1.3a/b-20
	Pending
	Pending

Block diagram

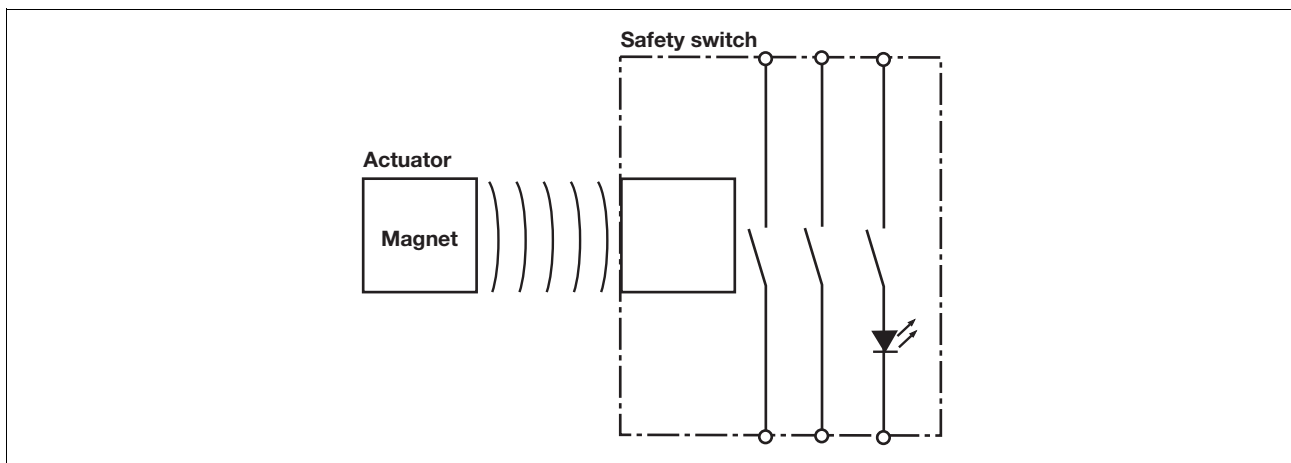

Function description

If the actuator is within the response range, the magnets switch the reed contacts on the safety switch. If the actuator is outside the response range (safety gate open), the reed contacts on the safety switch will switch.

PSENmag

PSEN ma1.3a/b-20

Operating distances

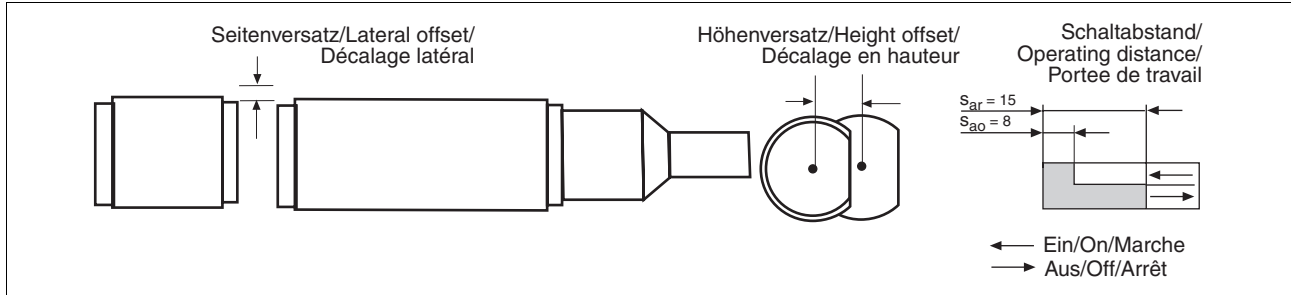

Lateral and vertical offset

with M12 actuator

- ▶ Assured operating distance S_{ao} in mm:

		Vertical offset		
		0	2	4
Lateral offset	0	8,0	7,0	5,5
	2	7,0	6,0	4,0
	4	6,0	5,0	3,0

- ▶ Assured release distance S_{ar} :
Max. 15 mm with all vertical and lateral offsets

The stated values are valid at a temperature of 20 °C.

Wiring

Please note:

- ▶ Information given in the “Technical details” must be followed.
- ▶ Calculation of the max. cable runs l_{max} in the input circuit:

$$l_{max} = \frac{R_{lmax}}{R_l / km}$$

R_{lmax} = max. overall cable resistance (see Technical details)
 R_l / km = cable resistance/km

- ▶ When using evaluation devices with delay-on de-energisation contacts, please note:
 - Delay time ≤ 30 s: Delay-on de-energisation contacts satisfy the requirements of category 3 in accordance with EN 954-1 and the requirements of a PDF with single-fault tolerance (PDF-S).
 - Delay time ≥ 30 s: Delay-on de-energisation contacts satisfy the requirements of Category 1 in accordance with EN 954-1 and the requirements of a PDF with designed reliability (PDF-D).
- ▶ In the following commissioning cases, check the function that detects shorts across contacts:
 - On evaluation devices with DC supply voltage: Overall cable resistance ≥ 15 Ohms per channel
 - On evaluation devices with AC supply voltage: Overall cable resistance ≥ 25 Ohms per channel
 - For details of how to perform the test for shorts across the contacts, please refer to the operating manual for the relevant evaluation device.

PSENmag PSEN ma1.3a/b-20

Connections

The safety switch is shown in an unoperated condition.

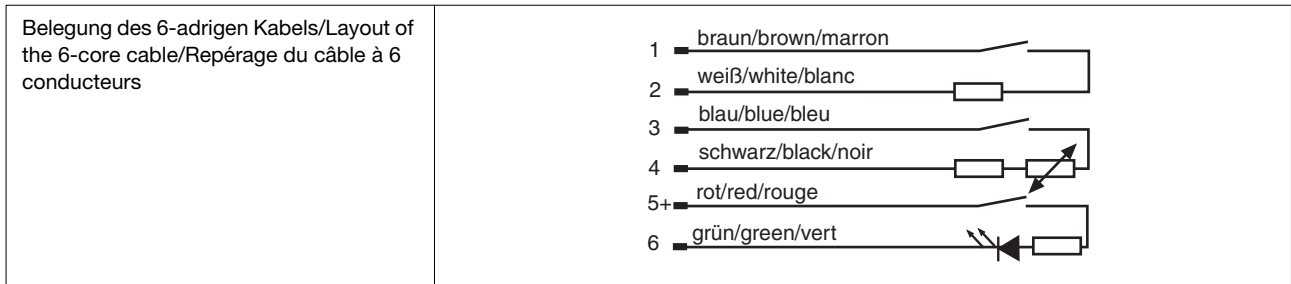

▶ Auxiliary contact with LED connection

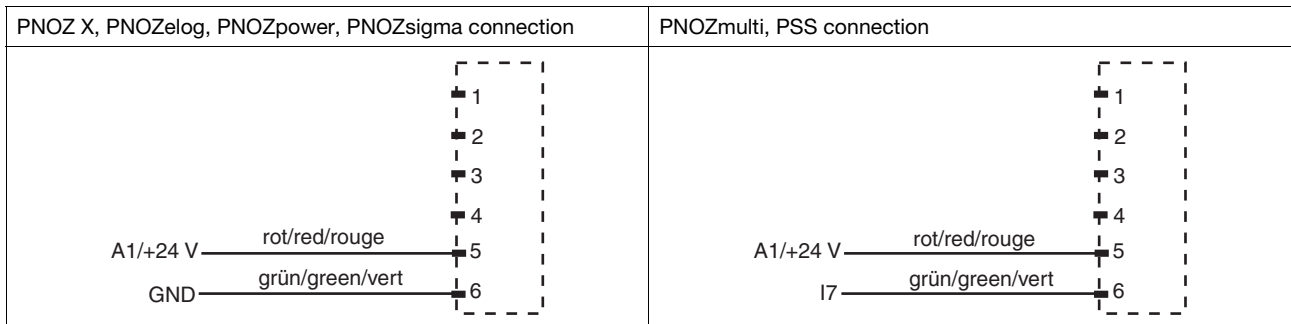

▶ Connection to PNOZ X, PNOZelog, PNOZpower, PNOZsigma

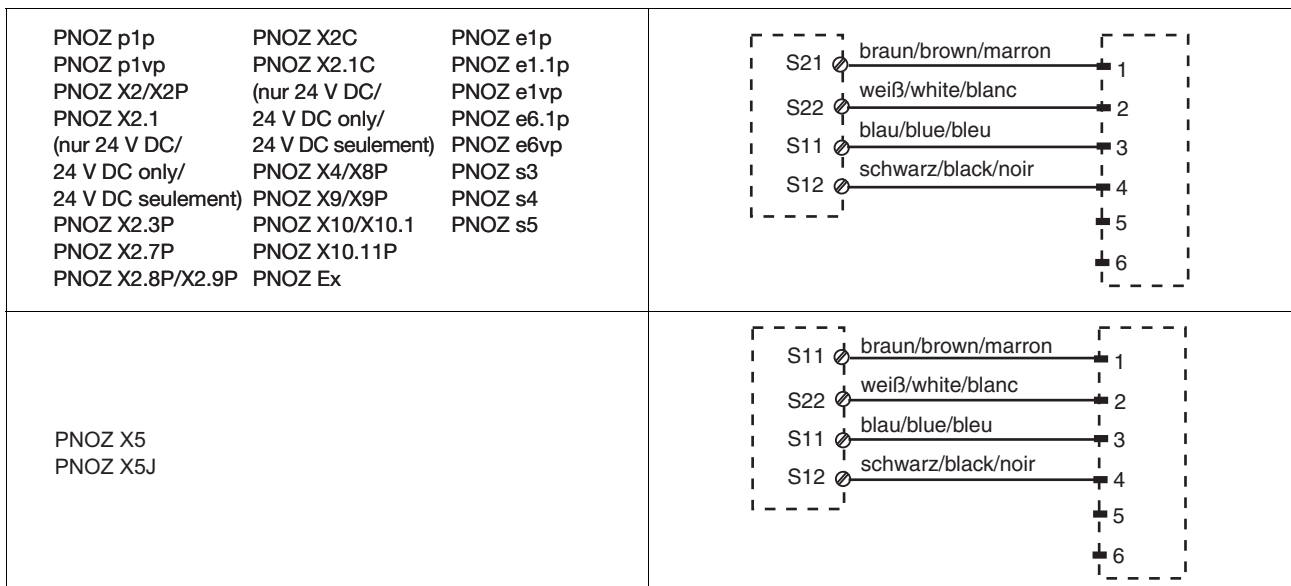

PSENmag PSEN ma1.3a/b-20

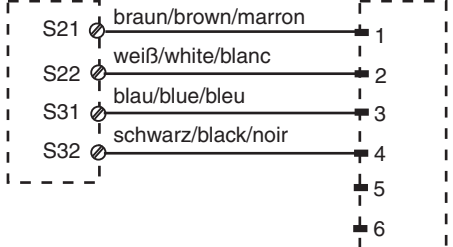
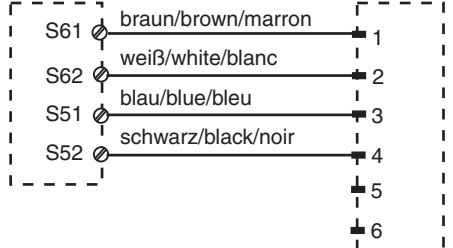
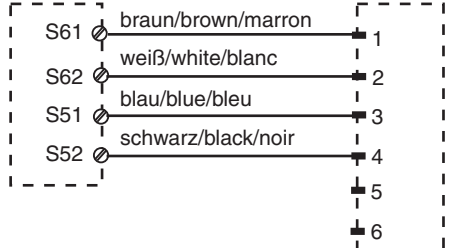
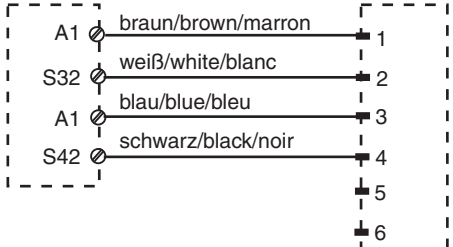
<p>PNOZ 11 PNOZ 16 PNOZ X11P PNOZ X13</p> <p>PNOZ X3.1 PNOZ X3P PNOZ X2.5P PNOZ X3</p> <p>PNOZ X3.10P PNOZ XV2 PNOZ XV2P PNOZ XV3 PNOZ XV3P</p>	
<p>PNOZ X6 (mit Brücke/with link/avec pontage Y3-Y4)</p>	
<p>PMUT X1P</p>	
<p>PNOZ e5.11p</p>	

► Connection to PNOZmulti

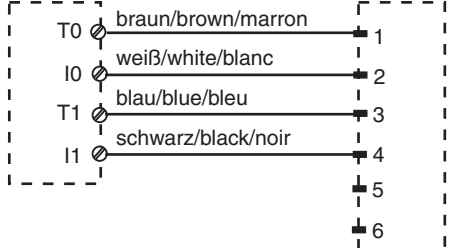
<p>Schutztür/safety gate/protecteur mobile Schaltertyp 3/switchtype 3/type du capteur 3 I0, I1: Eingänge/inputs/entrées T0, T1: Taktgänge/test pulse outputs/sorties impulsionnelles</p>	
--	--

PSENmag

PSEN ma1.3a/b-20

- ▶ Connection to PSS with and without SafetyBUS p

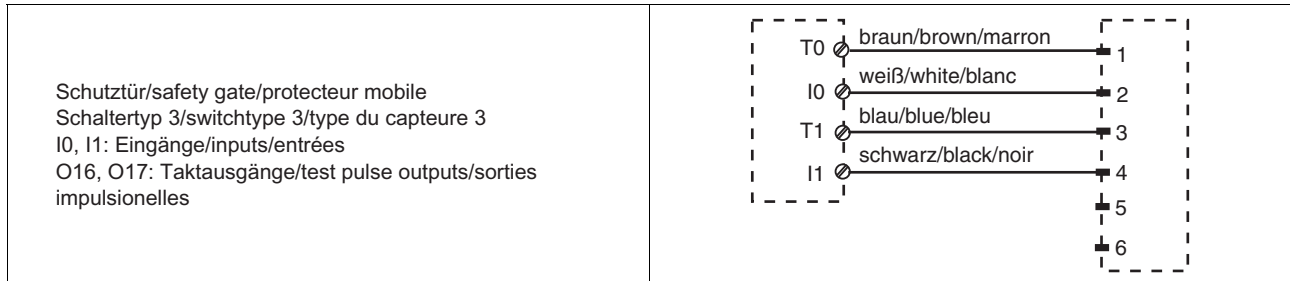

CAUTION!

The safety switches may only be operated on a PSS in conjunction with standard function block SB064 or SB066.

PSENmag PSEN ma1.3a/b-20

Installation

- ▶ When installing make sure you comply with the requirements of DIN EN 1088
- ▶ If possible, do not install the safety switch and actuator on to ferromagnetic material. Changes to the operating distances are to be expected.
- ▶ The distance between two systems comprising safety switch and actuator must be at least 25 mm.
- ▶ Safety switch and actuator
 - Keep away from iron swarf
 - Do not expose to strong magnetic fields
 - Do not expose to heavy shock or

vibration

- Do not use as a limit stop
- For fixed wiring only
- ▶ The unit can be installed in any position. The safety switch and actuator must be installed so that the bevelled surfaces face each other precisely.
- ▶ The safety switch and actuator should only be secured using M12 nuts made of non-magnetic material (e.g. Messing). Torque setting max. 300 Ncm.

Adjustment

- ▶ The safety switch may only be used with the corresponding actuator **PSEN ma1,3-08**.
- ▶ Always test the function with one of the approved evaluation devices.
- ▶ The stated operating distances (see Technical details) only apply when the safety switch and actuator are installed facing each other in parallel. Switching distances may deviate if other arrangements are used. Note the maximum permitted lateral and vertical offset (see "Operating distances" and "Max. lateral and vertical offset").

Dimensions in mm

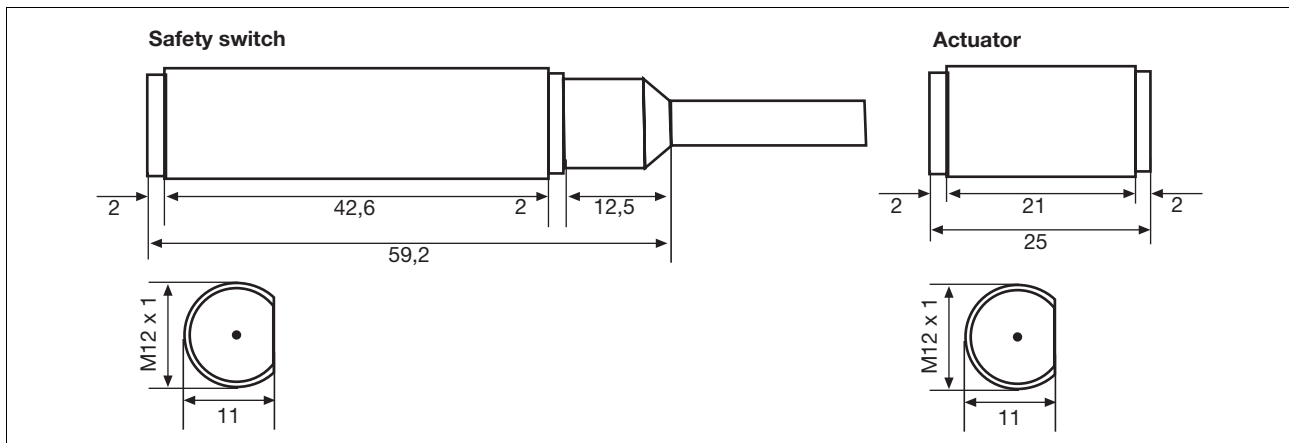

NOTICE

This data sheet is only intended for use during configuration. For installation and operation, please refer to the op-

erating instructions supplied with the unit.

Technical details

Switching distances	
Assured operating distance S_{ao}	8 mm
Min. operating distance S_{omin}	0.5 mm
Assured release distance S_{ar}	15 mm
Switching voltage	24 V
Max. switching current for reed contacts	0.20 A
Max. switching current for auxiliary contacts	10 mA
Max. breaking capacity for reed contacts	5.0 W
Max. switch frequency	1 Hz
Actuator	PSEN ma1,3-08
Ambient temperature	-25 - 70 °C

PSENmag

PSEN ma1.3a/b-20

Technical details	
Vibration to EN 60947-5-2	
Frequency	10 - 55 Hz
Amplitude	0.35 mm
Shock stress	30 g , 11 ms
Connection type	10m cable Order no.: 506222 5m cable Order no.: 506220
Cable	LiYY 6 x 0,25 mm²
Protection type	IP69K
Housing material	PBT
Dimensions	
Diameter	M12
Safety switch	
Depth	59.2 mm
Actuator	
Depth	25 mm
Weight	
Safety switch	220 g Order no.: 506220 430 g Order no.: 506222
Actuator	10 g

The standards current on **2007-03** apply.

Order reference				
Type	Quantity	Operation	Features	Order no.
PSEN ma1.3a-20	1/1	magnetic	Safety switch/actuator M12	506 220
PSEN ma1.3a-20 (switch)	1	magnetic	Safety switch	526 120
PSEN ma1.3b-20	1/1	magnetic	Safety switch/actuator M12	506 222
PSEN ma1.3b-20 (switch)	1	magnetic	Safety switch	526 122
PSEN ma1.3-08	1	magnetic	Actuator M12	516 120